

ARTICULIGHT

15-06 Morlot Avenue, Fair Lawn, NJ 07410 USA Tel: (201) 796-2690 Fax: (201) 796-8818

info@articulight.com

articulight@aol.com

www.articulight.com

LED SERIES

DMX TUBE®
LED RGB DMX TUBE



COLOR * TEXT * GRAPHICS * ANIMATION * VIDEO

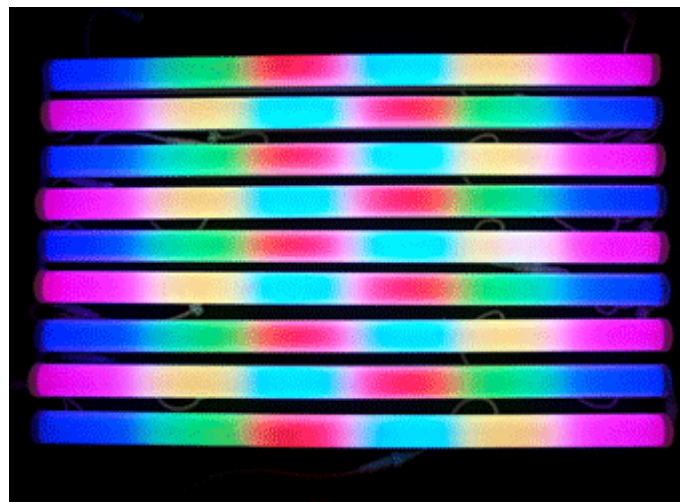

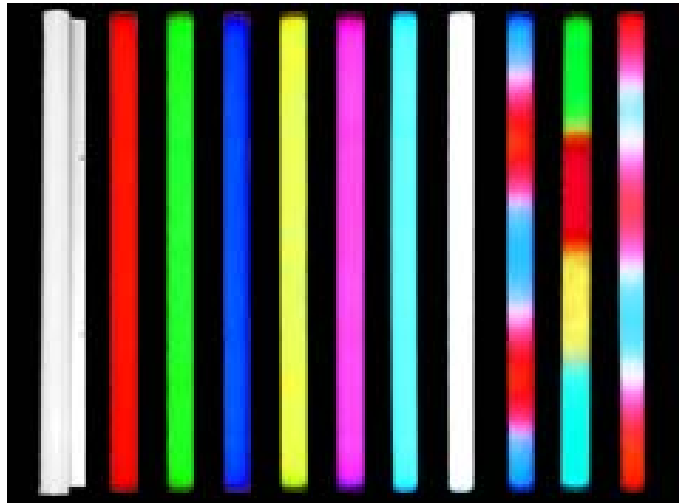

Imagine being able to change color, create patterns and move them along a tube. Now you can with the aptly named **DMX TUBE®**. Instead of neon or fluorescent, an array of LEDs fills each tube. It looks like neon or fiber optics, yet it does much more.

The **DMX TUBE®** instantly comes to life with flowing, fading, chasing and ebbing streams of colored light. Custom patterns run automatically or are triggered from existing control systems. Visual effects that were previously impossible are now simple to create and control.

Each section contains individually controllable pixels comprised of red, green, and blue LEDs. Pixels can be uniform for a solid color effect or different to create color patterns. Color patterns can move at varying speeds and continue through linked units.

The **DMX TUBE®** enables direct DMX input for professional programming and control of vibrant color patterns and dynamic visual effects.

The **DMX TUBE®** lighting effect is powered by LED technology which offers:

Ultra-long lamp life
Minimal maintenance

Low heat emission, No UV and IR
Low power consumption
Easy installation

The LED DMX Tube is a graphics and color changing grade tub that can be set to 1, 2, 4, 8, and 16 pixels per tube. LED DMX Tubes come in half meter (500mm) and 1 meter versions. The LED DMX Tube uses the very latest in high quality (RGB) LED's to provide high luminosity even and consistent colors. The LED DMX Tube can be directly controlled by DMX-512, PC Graphics Control, or a stand-alone graphics playback systems.

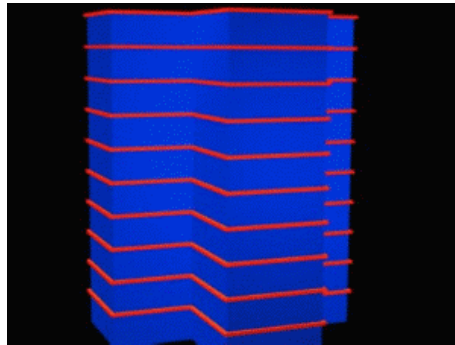
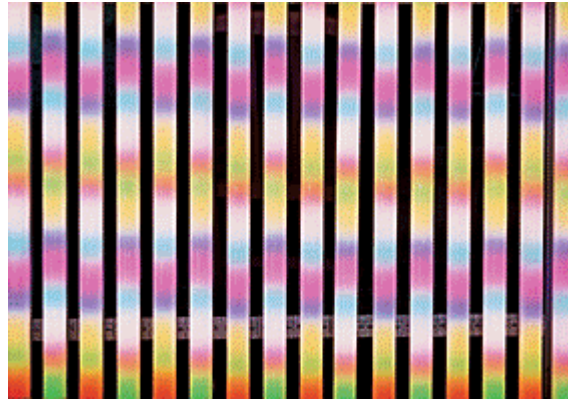

ADVERTISING * PROMOTION * ARCHITECTURAL * DISPLAY *
ENTERTAINMENT * RETAIL * SIGNAGE



FEATURES

- LED environment-friendly long life light source
- Advanced RGB color-mixing technology
- Energy efficiency (maximum 16.8 W per meter)
- Resistance to direct sunlight
- Intelligent control system for lighting effects
- No additional power or control boxes required with the unique built-in power + data unit
- Intelligent auto-protect function
- Durable enclosures made of selected materials
- Virtually no gap when units are butted end to end

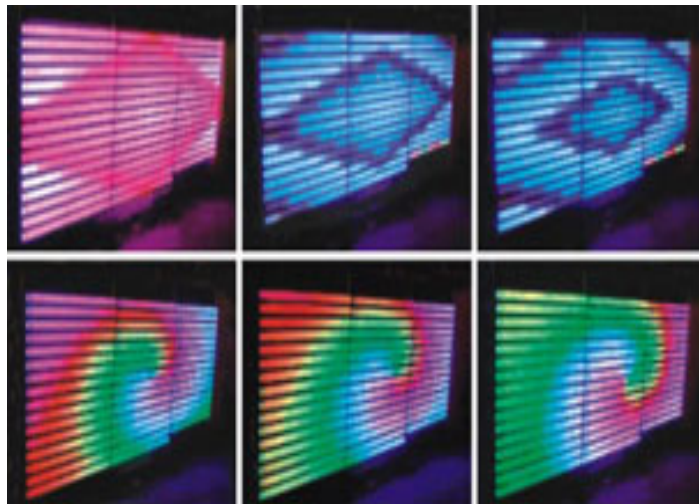

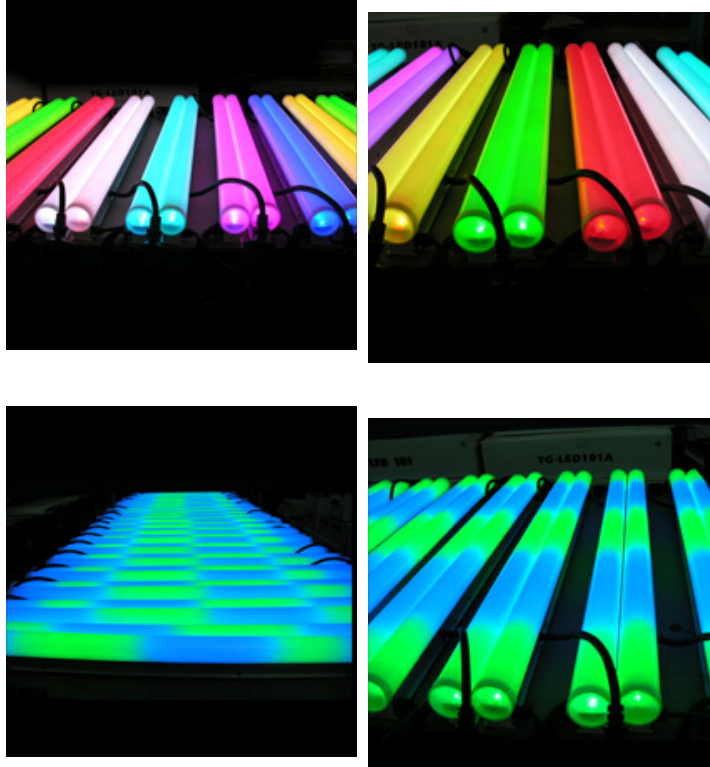

TECHNICAL DATA

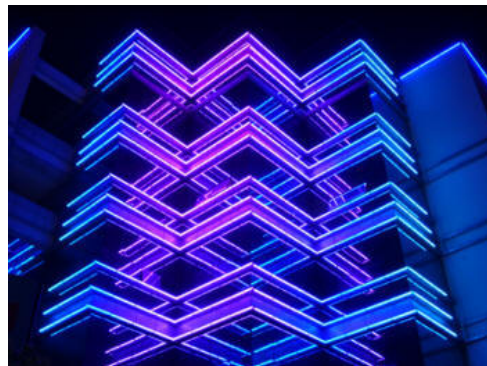

Tube Diameter: 50 mm (5cm)

Tube Length: 1 meter (100cm)

Dimensions: L1000 x W50 x 75mm

Weight: 1.5 kgs

Voltage: Line voltage: AC 100 V - 240 V; Inside power supply :12 v

Current: 20-25 mA

Counter current: 5 uA

Frequency: 50/60 Hz

Power: 16.8 W maximum, 1.4A

Number of LEDs: 144 ultrabright bulbs

LED bulbs: RGB color mixing (48 Red, 48 Green, 48 Blue) with 4 or 8 separate sections per color

Life Span: 100,000 hours

Luminance: 64 lumens

Controlling mode: dynamic or static

Control: DMX512 in DMX mode or dedicated controller.

Individual Control: SRC-236DL controller

Computer Control: PC + SRC-236DL controller

DMX Controller: Universal DMX 512 controller

Signal Input Connector: 5 pin male connector

Signal Output Connector: 5 pin female connector

DMX Channels:

DMX Channel 1: Red,

DMX Channel 2: Green,

DMX Channel 3: Blue,

Colors: red, yellow, white, purple, cyan, green, blue or changeable

Color change: RGB color mixing, solid state, no motors!

Color Change Modes: Color Change

Slow flow (unidirectional flow)

Slow flow (bidirectional flow)

Roll Chase 1 (rolling backward and forward)

Roll Chase 2 (scan backward and forward)

Multi Color chase

Fast flow 1 (unidirectional flow)

Fast flow 2 (bidirectional flow)

2 color chase

2 color flow

Gray scale color change

Dynamic picture effect

Brightness: Red: 700-1300 mcd; blue: 465-474 mcd; green: 1500-3000 mcd

Wavelength: Red: 625-640 nm; Blue: 465-474 nm; Green: 515-524

Beam Angle: >120 degrees

Side View: 122 degrees

End View: 200 degrees

Working environmental temperature: -40 C to 80 C (-4 to 140 degrees F)

Operating Humidity: 0-95%

Housing: Aluminum alloy (anti-UV)

Tube composition: clear or milky white optically diffused polycarbonate (PVC)

Installing Methods: 1. channels screws into installed brackets 2. channels snaps into installed bracket

Color adjustable code: 256 grade

IP Rating: IP 65 <http://www.articulight.com/acc/IPRatings.html>

UL and CE approved: Yes

Signal Amplifier: already set inside the tube

Power Supply: already set inside the tubes

Recommended DMX Tubes to design In:

1. Mounting surface
2. Mounting plate
3. Fixing plates
4. DMX Tube

The DMX Tube is mounted as shown below. The mounting plate (2) is attached to the surface to be mounted(1). The DMX Tube (4) is placed against the mounting plate (2) and secured by the fixing plates (3).

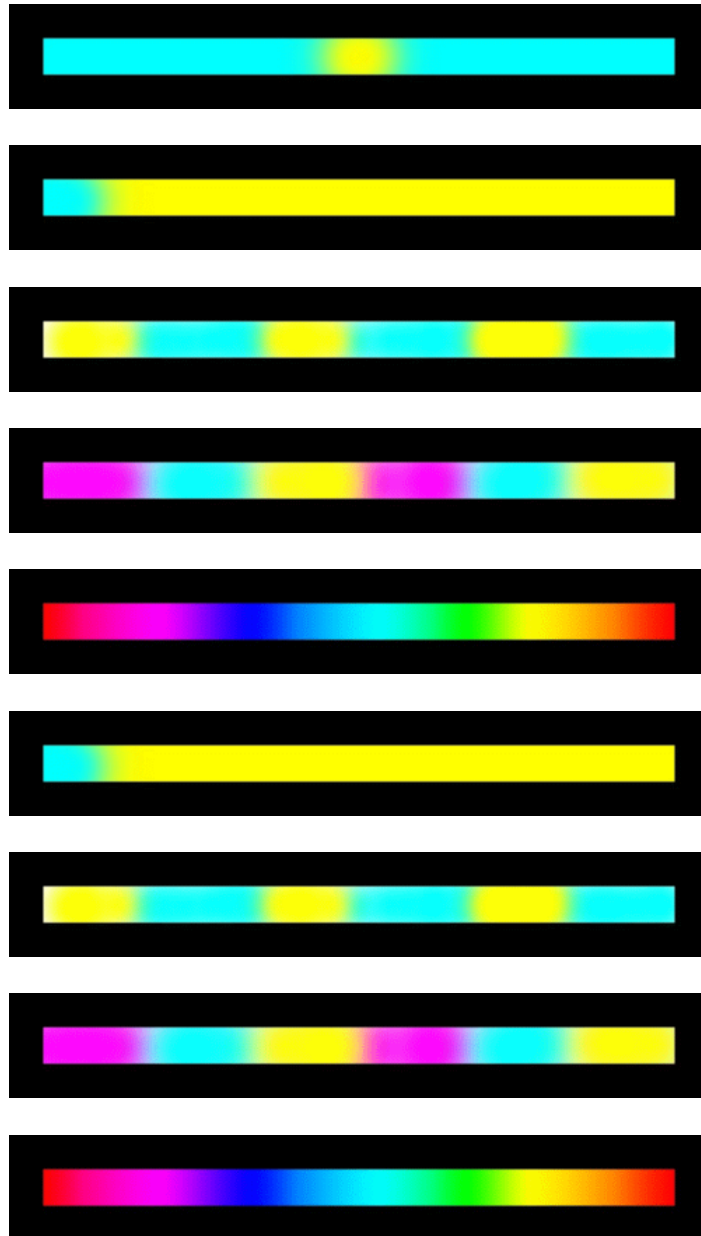
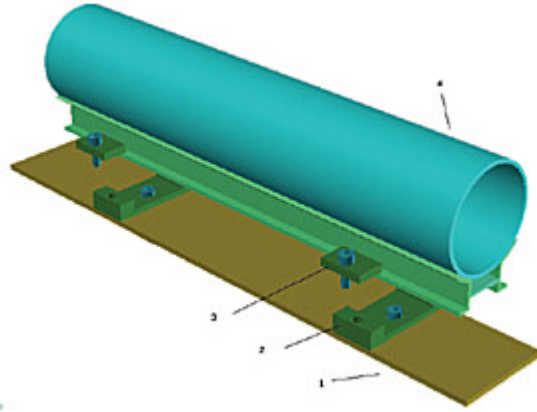



Dimensional Diagrams

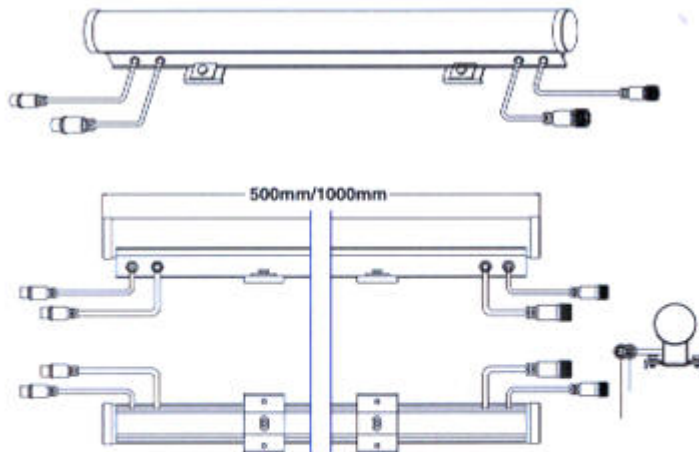

Connection Diagrams

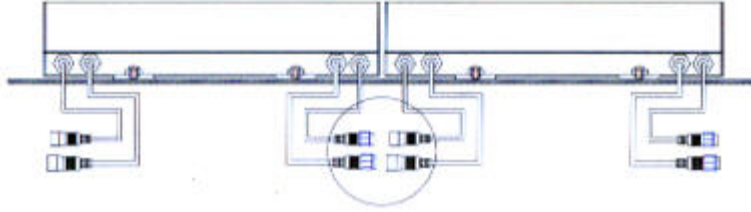

Suggestions: Please install the same way as these diagrams and the diagrams located in your products user manual. After the connectors are joined together, the female connector should be on top and the male connector at bottom to improve the waterproofing effect.

Candle Power Distribution

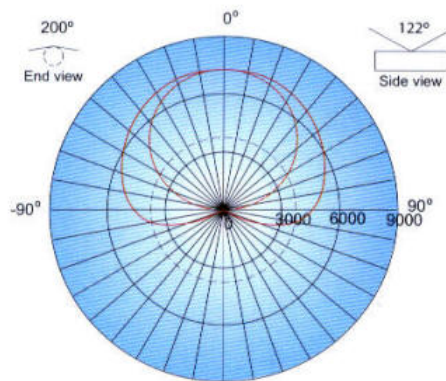

End view (solid line) and Side view(dashed line) (candelas)	
Measure on:	White
Beam center:	7400mcd
Thin dashed lined:	Indicates 50% of peak value
Multipliers:	0.07R, 0.57G,0.36B

Connection Variations (Control Type Dependent)

PC or Stand-alone Matrix Connection
 PC or Stand-alone Matrix Connection

This configuration requires the additional hardware listed below:
 SRC-236DL Controller-or- SRC-236DL Controller and PC SDL-109A-T1(Quantity based on total number of tubes)

Example 1:

As Illustrated above: 2 sections per tube, 16 pixels per tube, 3 channels per pixel, 48 channels per tube

Use the SRC-236DL Ver1.2 Controller to write the DMX address into the tube memory by connecting the controller to the first tube. With all tubes connected assign in the controller menu the start address of the first tube and follow the instructions in the user manual to complete the write to memory process. One DMX Universe equals 10 tubes. Only 1 DMX Universe can be used in Standard DMX mode per 10 tubes. Once the memory has been written and the dmx addresses assigned you can connect a standard DMX controller to the tube matrix via the 5-pin DMX connector. To use more tubes in 48 channel mode a PC and PC Software in conjunction with the SRC-236DL ver1.2

Light Output

LN-MC-1000-DMX				
Color	White	Red	Green	Blue
Total Output(lumens)	63.9	10.5	42.3	14.6
Power (Watts)	12	2.4	4.8	4.8
Efficacy (lm/W)	5.3	4.4	8.8	3.0

DMX Functionalty Chart

Mode	# of DMX Channels	1	2	4	8	16	Channel	Name	Value	Function
1 Pixel	3	Blue	Yellow	Green	Purple	Orange	1	Red	0~255	0~100% intensity
		Blue	Yellow	Green	Purple	Orange	2	Green	0~255	0~100% intensity
		Blue	Yellow	Green	Purple	Orange	3	Blue	0~255	0~100% intensity
		Blue	Yellow	Green	Purple	Orange	4	Red	0~255	0~100% intensity
		Blue	Yellow	Green	Purple	Orange	5	Green	0~255	0~100% intensity
2 Pixels	6	Blue	Yellow	Green	Purple	Orange	6	Blue	0~255	0~100% intensity
		Blue	Yellow	Green	Purple	Orange	7	Red	0~255	0~100% intensity
		Blue	Yellow	Green	Purple	Orange	8	Green	0~255	0~100% intensity
		Blue	Yellow	Green	Purple	Orange	9	Blue	0~255	0~100% intensity

						10	Red	0~255	0~100% intensity
						11	Green	0~255	0~100% intensity
4 Pixels						12	Blue	0~255	0~100% intensity
						13	Red	0~255	0~100% intensity
						14	Green	0~255	0~100% intensity
						15	Blue	0~255	0~100% intensity
						16	Red	0~255	0~100% intensity
						17	Green	0~255	0~100% intensity
						18	Blue	0~255	0~100% intensity
						19	Red	0~255	0~100% intensity
						20	Green	0~255	0~100% intensity
						21	Blue	0~255	0~100% intensity
						22	Red	0~255	0~100% intensity
						23	Green	0~255	0~100% intensity
8 Pixels	24					24	Blue	0~255	0~100% intensity
16 Pixels	48					25-48	Red	0~255	0~100% intensity

DUE TO CONTINUOUS IMPROVEMENTS, SPECIFICATIONS MAY CHANGE WITHOUT PRIOR NOTICE.