

ARTICULIGHT

15-06 Morlot Avenue, Fair Lawn, NJ 07410 USA Tel: (201) 796-2690 Fax: (201) 796-8818

info@articulight.com

articulight@aol.com

www.articulight.com

LED SERIES

LED GARDEN 105®



The LG-105-24V-M LED Garden 105 lamp is designed and rated for permanent outdoor use. The LG-105-24V-M is available in static colors: red, green, blue, white. LED Garden 105 lamps are controlled by external controllers, allowing lights to function in stand-alone mode, or as DMX interface for integrating tubes systems into already existing DMX networks.

Recommended LED GARDEN 105 Products to Design:
Gardens, parks, decks, parks and walkways.



TECHNICAL DATA

Power:	1.44W
Cylinder Diameter:	60MM
Ø5 LED'S:	10 red, 6 green, 6 blue
Product Dimensions:	L150xW150xH269.5mm
Weight:	1950g

Installation of LG-105-24V-M

LG-105-24V-M is mainly suitable for install in grassland, floor and any other place that can fix it. fix the base in the floor (if it is earth, please keep the bottom or other base at the same line of the floor, if it is cement or other concrete, please just set the base into the floor, leaving the upper side of the base at the same level of the floor.

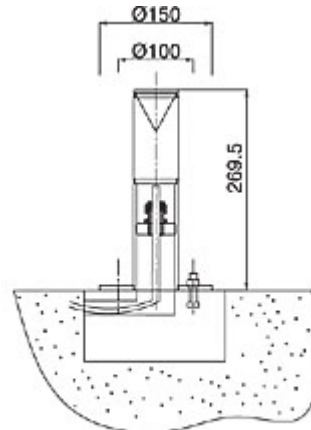

1. LG-105-24V-M
2. Grassland, floor

Connecting to the SRC-171 controller.

Please note that the connecting method just same as LG-100-24V-M. When the distance between 2 pieces of LG-105-24V-M is within 3 meters, one SRC-171 can control up to 20 pieces of LG-104-24V-M. When the distance is within 2 meters, one SRC-171 can control up to 25 pieces of SDL-104. When the distance is within 1.5 meters, one SRC-171 can control up to 30 pieces of LG-104-24V-M. Connecting way is shown as bellow:

Connecting to DMX controller

For DMX Controller, the connecting method & function just same as LG-100-24V-M.

