



15-06 Morlot Avenue, Fair Lawn, NJ 07410 USA Tel: (201) 796-2690 Fax: (201) 796-8818

info@articulight.com

articulight@aol.com

www.articulight.com

LED SERIES

MARATHON 60 LED STREETLIGHT



MARATHON60 is a new, energy-saving street light product that utilizes high-power LEDs as a light source. It can be directly connected with a 100-240V AC power supply. In the LED color spectrum, there is no ultraviolet light, no infrared rays, no heat, and no radiation produced. As a result, MARATHON 60 is a conventional "green" lighting source. The lamp casing is made of aluminum-alloy through die-casting. The lamp cover material uses high quality toughened glass, which is highly lucent, dust proof and waterproof., The whole set uses stainless steel fasteners. The surface of the product is covered with fluorocarbon powder that is sprayed on in electrostatic spraying manner, resulting in a good self-cleaning property. The product is safe, reliable, and has low energy-consumption and a long life span. It is especially suitable for use in public places such as open squares, streets and roads just to name a few.

MARATHON SOLAR 60 street light is a more eco-friendly product by utilizing solar energy as a resource. The whole set uses stainless steel fasteners.

MARATHON60 with Light & Time control (AST) is an additional function. LED

street light can turn on and turn off automatically according to the light sensor, when the illuminance gets lower than 13 LUX, the light comes on; otherwise, it keeps it off. When the illuminance gets higher than 50 LUX, the light goes off. It needs 5 minutes in the process of on and off switching. In the early 6 hours' working time, the light shines at its maximum power, and in the late 4 hours, the light shines at its half power.

The above function just can be set according to the customers' requests in the factory, and customers cannot set it themselves.

Plane iso-illuminance curve:

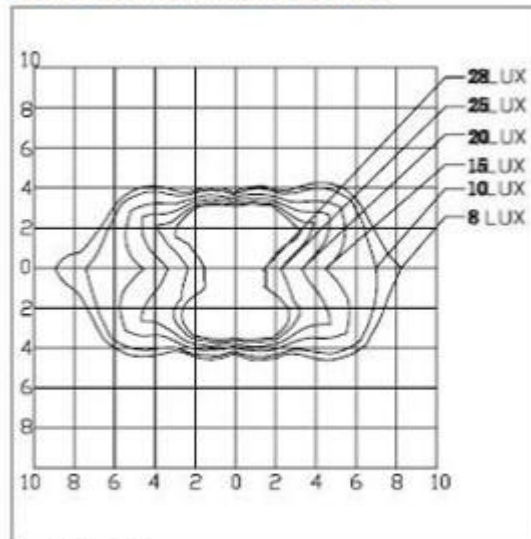

Height: 6M
Max illuminance: 38.17 LUX

Luminous Intensity Distribution:

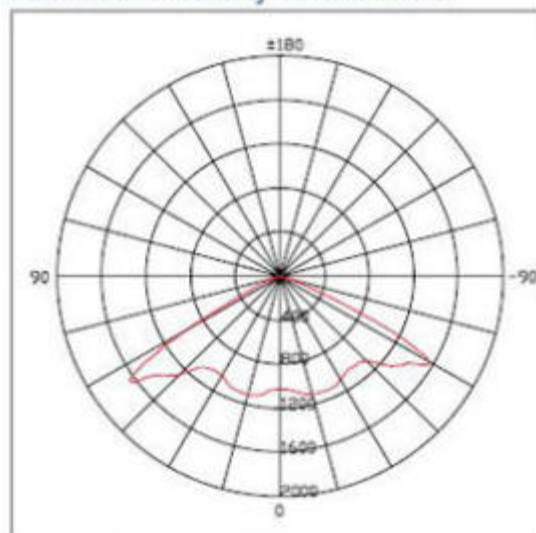

Max Luminous: 1639.49cd



Technical Specifications

MODEL	STR2019-000	STR2018-110
Type	MARATHON60(Head Unit)	MARATHON 30(Single Head)
Light source	60x1W high power LED	
Color temperature	2000K±200K; 6500K±500K	
Luminous flux	3880Lm	
Average Illumination	22Lux/6m	
Area of Illumination	±9m (29.52 ft)	
Input voltage,frequency	100-240V AC,50/60Hz	
LED operating current	24V DC	
Total LED power	78W	
Installation tube diameter	Ø50mm (Max.)	NA
Peak wattage of solar module	NA	
Working Environment	-30°C-+40°C	

Note

STR2019-101
 The Auto Switching Technology (AST) sensor is located on the adjoining bracket between the pole coupler and the LED fixture. AST works by Auto Switching "turning on" the High Power LED Street Light when the luminance of sunlight is lower than 13 LUX and off again when a LUX factor greater than 13 is sensed. AST=Automatic Switching Technology

Dimensions of Framework

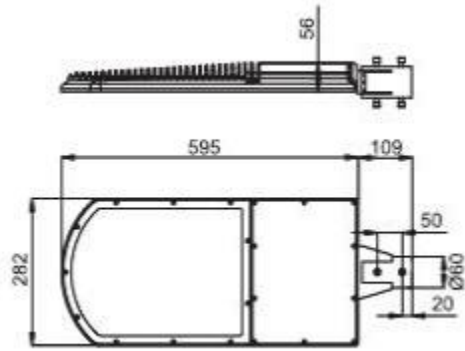

STR2019-000

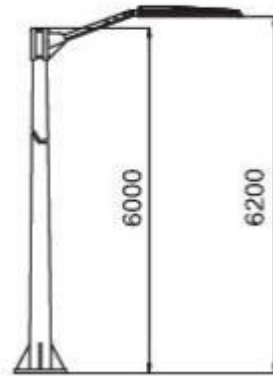
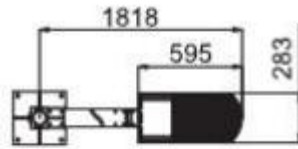

**STR2019-100
STR2019-101**

DUE TO CONTINUOUS IMPROVEMENTS, SPECIFICATIONS MAY CHANGE WITHOUT PRIOR NOTICE.